



PMT glass window sensitivity to gamma-rays: A digital signal processing approach

Based on :<https://doi.org/10.1016/j.nima.2020.163401>

M. Ghahremani Gol, M. Khakzad, S. Jamili, N. Ghal-Eh

Speaker: Dr. Maryam Ghahremani, IPM

Time: Wednesday, July 1st, 2020, 11:00 AM

Wednesday Weekly Seminar



Contents lists available at ScienceDirect

Nuclear Inst. and Methods in Physics Research, A

journal homepage: www.elsevier.com/locate/nima

Technical notes

PMT glass window sensitivity to gamma-rays: A digital signal processing approach

M. Ghahremani Gol^{a,*}, M. Khakzad^a, S. Jamili^a, N. Ghal-Eh^{b,c}^a School of Particles and Accelerators, Institute for Research in Fundamental Sciences (IPM), P.O. Box 19395-5531, Tehran, Iran^b School of Physics, Damghan University, P.O. Box 36716-41167, Damghan, Iran^c Department of Physics, Faculty of Sciences, Ferdowsi University of Mashhad, P.O. Box 91775-1436, Mashhad, Iran

ARTICLE INFO

Keywords:

Photomultiplier tube (PMT)
Scintillation detector
Time response
Digital pulse processing

ABSTRACT

A digital data acquisition system together with MATLAB software for data analysis were utilised to measure the pulse specification of the scintillation detector assembly. Besides, the sensitivity of a photomultiplier tube (PMT) window to gamma-rays was studied to discriminate the signals produced as a result of gamma-ray interactions inside the glass window from those originating from the scintillator cell. The result showed that an algorithm based on the time features was capable to evaluate the contributions of these two different signals.

1. Introduction

The PMTs are the most appropriate tools for detecting visible, ultraviolet, and near-infrared radiations due to their high sensitivity, low-noise and fast response, which are widely used in different applications ranging from particle and nuclear physics to astronomy and space sciences [1]. In PMTs, the photons incident on the photocathode are converted to electrons which are further accelerated toward the first dynode before they are multiplied within the dynode chain whose potential differences are maintained by an appropriate voltage-dividing circuit [2].

Scintillation detectors are commonly used in various applications and radiation fields, from radioactivity measurements and imaging

Bayat et al. [11] where they concluded that this effect was significant especially in low-efficiency scintillation detectors.

The glass window scintillation basically put a limit on the use of PMTs in some specific applications such as coincidence measurements, time-of-flight studies and intrinsic efficiency assessment [12]. Therefore, the discrimination of signals originating from the scintillator cell from those associated with the glass window is an essential task to undertake.

In general, the pulse-shape analysis of the PMT output signal provides unique information that can be used in energy sensitivity and fast time response measurements as well as particle type identification studies

Abstract

A digital data acquisition system together with MATLAB software for data analysis were utilised to measure the pulse specification of the scintillation detector assembly. Besides, the sensitivity of a photomultiplier tube (PMT) window to gamma-rays was studied to discriminate the signals produced as a result of gamma-ray interactions inside the glass window from those originating from the scintillator cell. The result showed that an algorithm based on the time features was capable to evaluate the contributions of these two different signals.

Outline

- **Motivation**
- **Photomultiertube (PMT)**
- **Plastic Scintillator detector**
- **Data Acquisition system**
- **The experimental setup**
 - 1) The spectra obtained from the detector with a bare PMT
 - 2) The count rates of the PMT output pulses measured with a bare PMT, with and without extra glasses, when exposed to ^{60}Co point source
 - 3) The discrimination of the plastic scintillator pulse from the pulse originating from the PMT glass
- **Conclusions**

Motivation

- ✓ In a comprehensive work undertaken by Krall ,it was observed that there were excess light generations for the detector exposed to low energy gamma-rays and charged particles, for which the scintillation within the PMT glass window was believed to be the main reason.
- ✓ The scintillation in the PMT had been also confirmed by Anderson where several PMT types where examined with proton beam irradiations.
- ✓ The glass window scintillation basically put a limit on the use of PMTs in some specific applications such as coincidence measurements, time-of-flight studies and etc.
- ✓ In general, the pulse-shape analysis of the PMT output signal provides unique information that can be used in energy sensitivity and fast time response measurements as well as particle type identification studies.

Therefore, the discrimination of signals originating from the scintillator cell from those associated with the glass window is an essential task to undertake.

Photomultiertube (PMT)

The PMTs are the most appropriate tools for detecting visible, ultraviolet, and near-infrared radiations due to their high sensitivity, low-noise and fast response, which are widely used in different applications ranging from particle and nuclear physics to astronomy and space sciences . In PMTs, the photons incident on the photocathode are converted to electrons which are further accelerated toward the first dynode before they are multiplied within the dynode chain whose potential differences are maintained by an appropriate voltage-dividing circuit.



Photomultiplier Tubes (PMT)

A PMT consists of

- input window
- Photocathode
- focusing electrodes
- electron multiplier
- and an anode

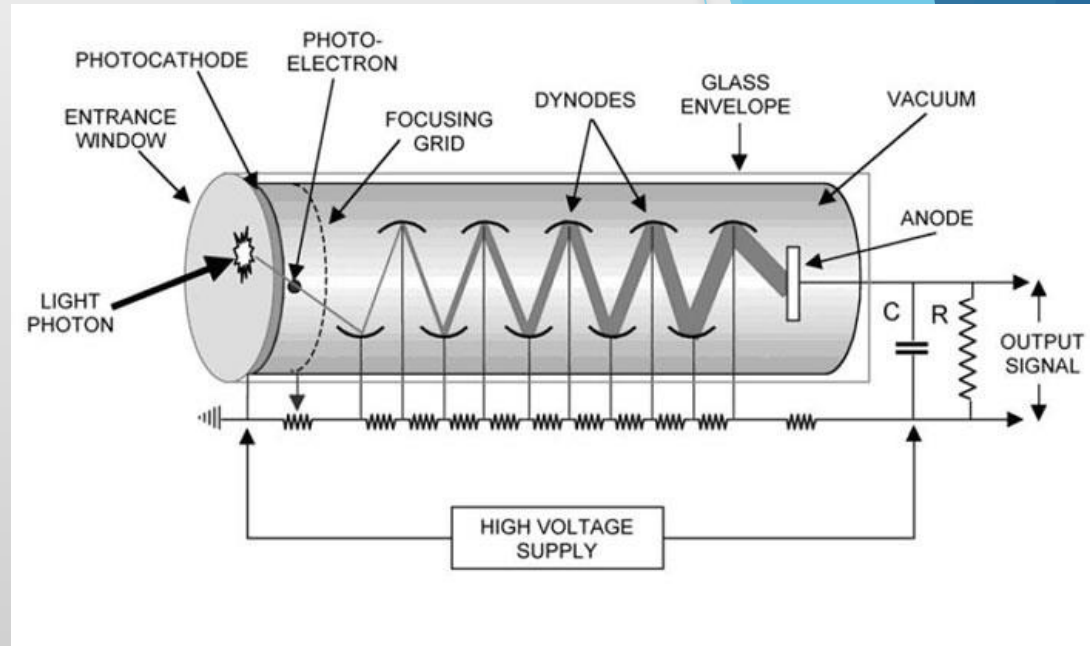

Scintillators

Scintillation detectors are commonly used in various applications and radiation fields, from radioactivity measurements and imaging in industry and medicine to high-energy particle physics and astrophysics experiments. When an ionizing radiation passes through the scintillators, it interacts within the scintillator cell and produces secondary-charged particles (*e.g.*, electrons and protons as a result of gamma-rays and neutrons, respectively), whose partial deposition energies are further converted to a flash of visible or near-visible light. Since the scintillators are generally transparent to their own scintillation photons, these so-called optical photons easily reach to photosensitive region, the PMT, where they are converted to photoelectrons.

Scintillators – General characteristics

Principle:

- dE/dx converted into visible light
- detection via photo sensors [e.g. photomultiplier, SiPMs...]

Features:

- sensitive to energy
- fast time response
- pulse shape discrimination

Types of scintillators

Inorganic Scintillators @ **expensive**

Advantages:

- ✓ high light yield
- ✓ high density
- ✓ good energy resolution

Disadvantages:

- ✓ complicated crystal growth
- ✓ large temperature dependence

Organic Scintillators @ **cheap**

Advantages:

- ✓ very fast
- ✓ easily shaped
- ✓ small temperature dependence

Disadvantages:

- ✓ lower light yield
- ✓ radiation damage



Applications



Projectional radiography

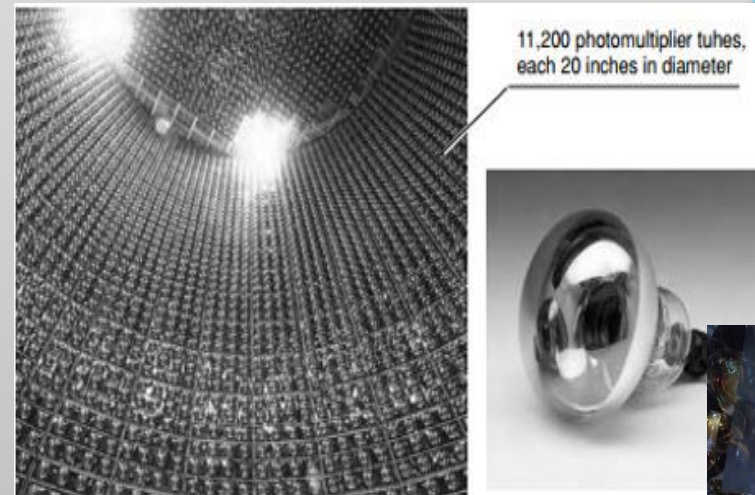
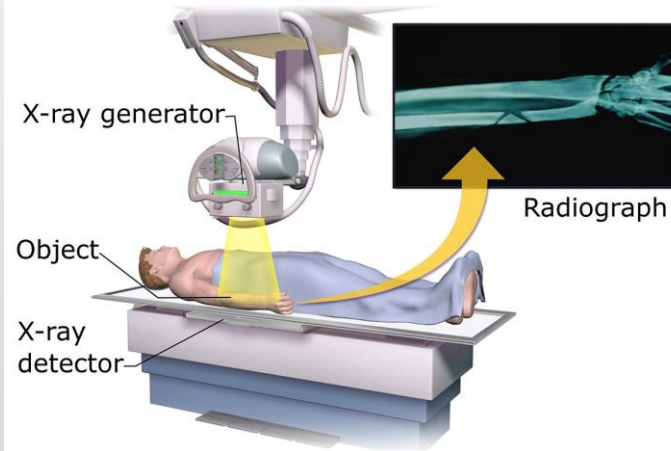

Scintillators – basic setup

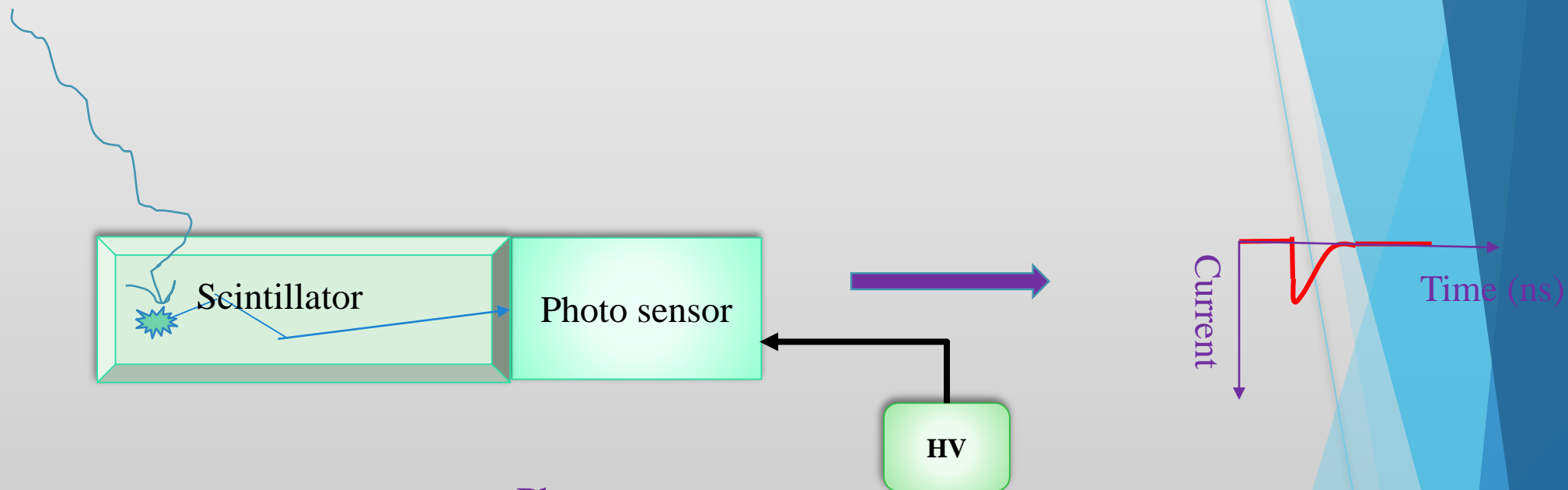

Scintillator Types:

- organic scintillators
- inorganic crystals
- gases

Photo sensors:

- photomultipliers
- micro-channel plates
- hybrid photo diodes
- silicon photomultipliers (SiPMs)

Plastic Scintillators

Step 1

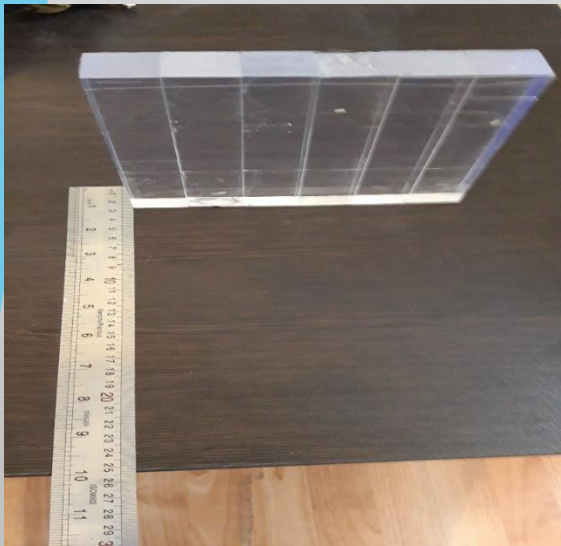

Step 2



Step 3



Components and Principle of detection Mechanism

Traditional method

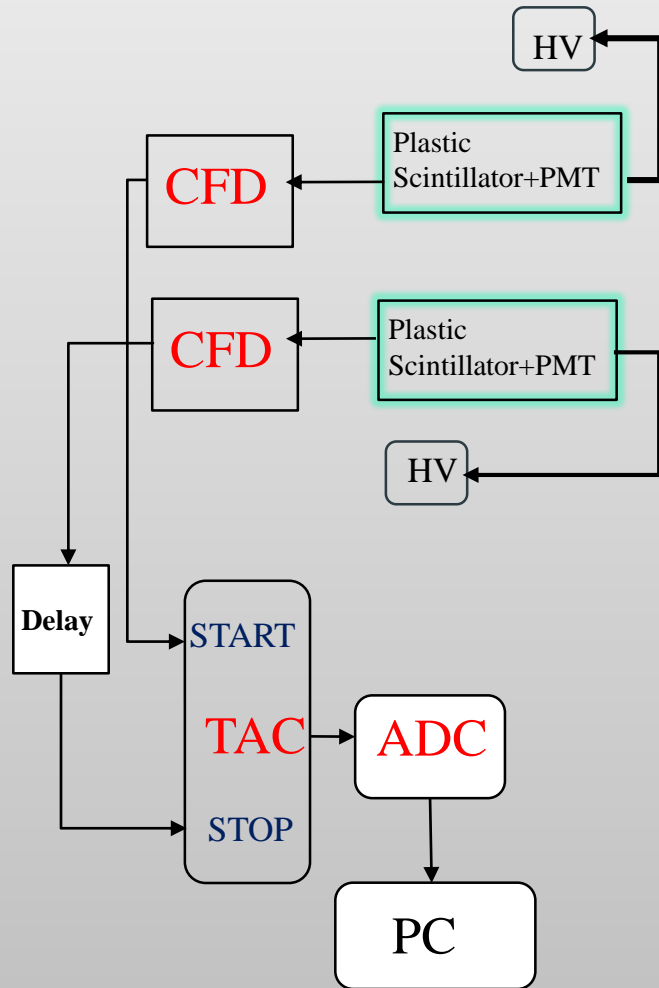

- ✓ Constant Fraction Discriminator (CFD)
- ✓ Time to Amplitude Converter (TAC)
- ✓ Analog to Digital Converter (ADC)

Classic method

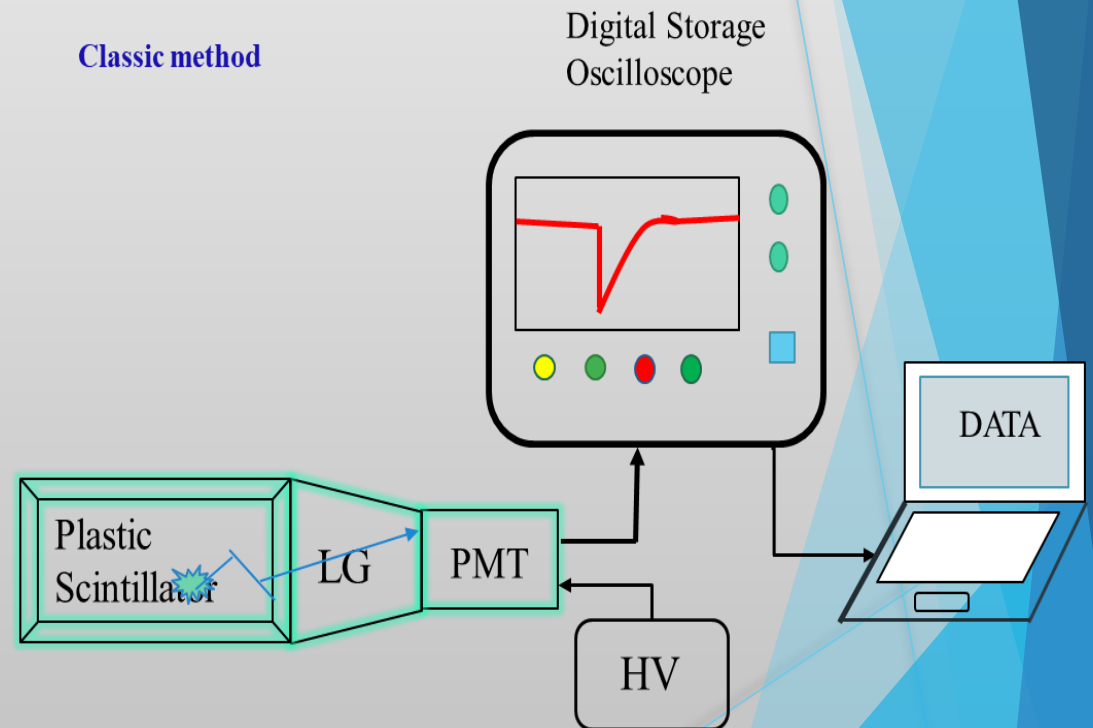

Data Acquisition

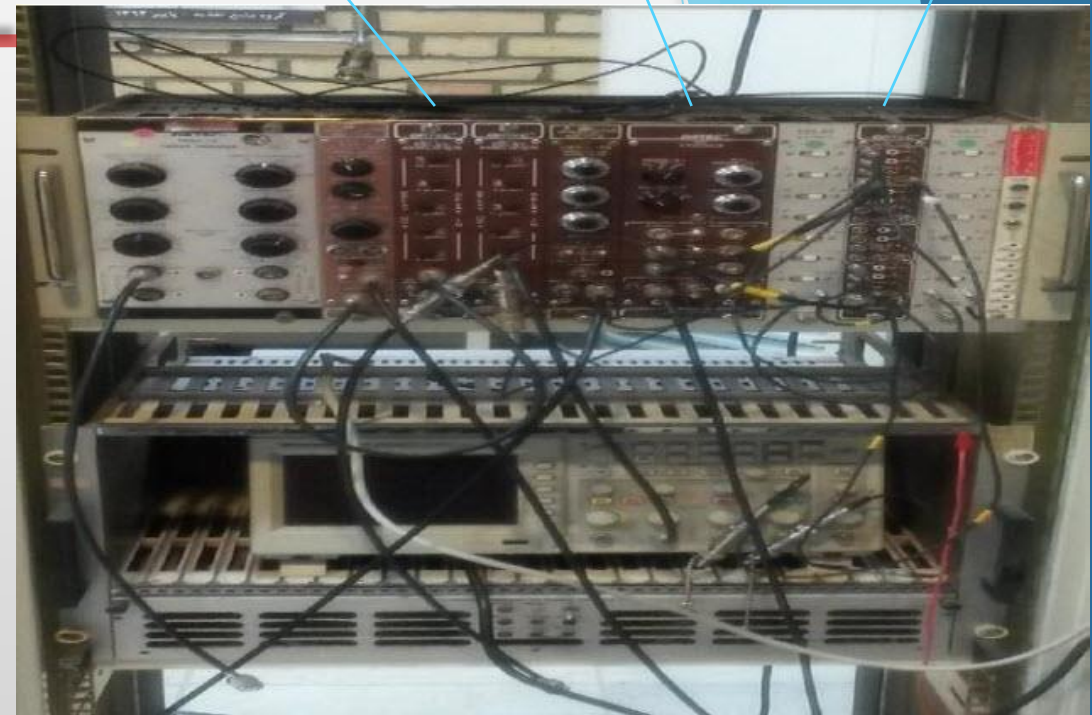
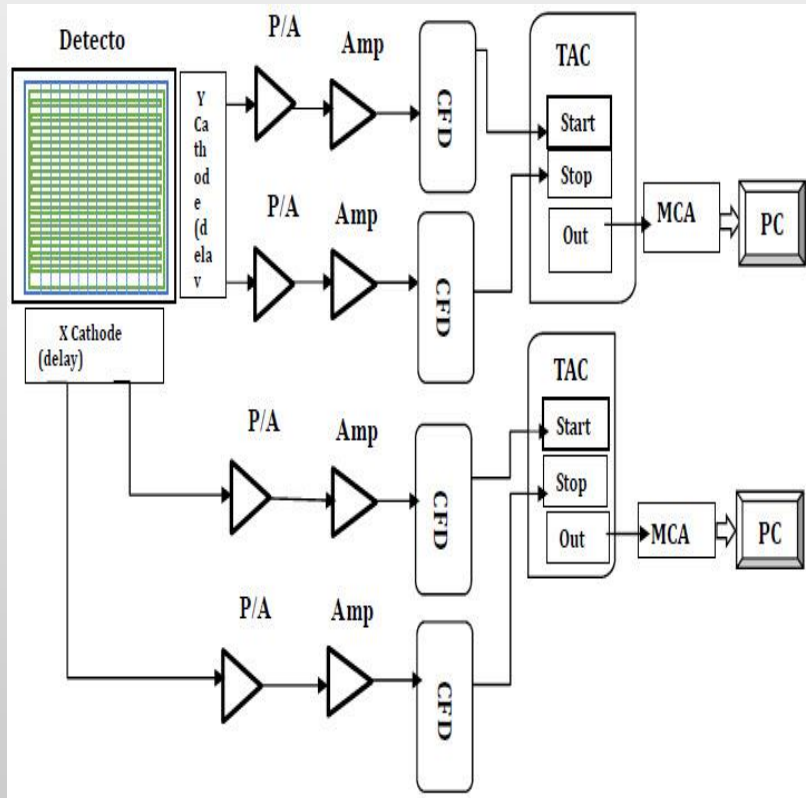

Data Acquisition

Digital Storage Oscilloscope

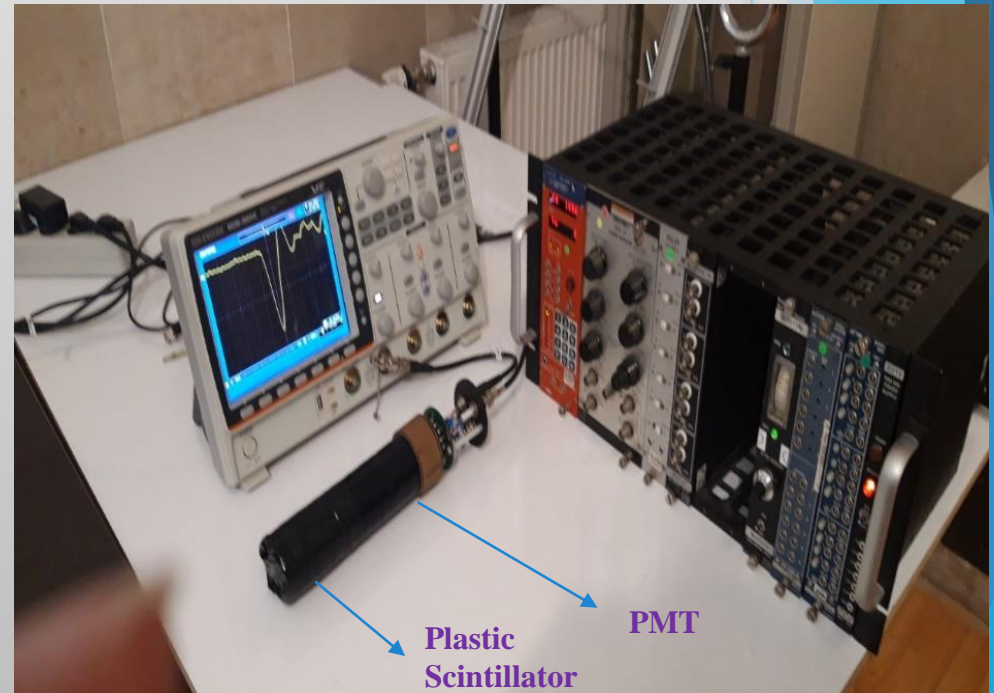
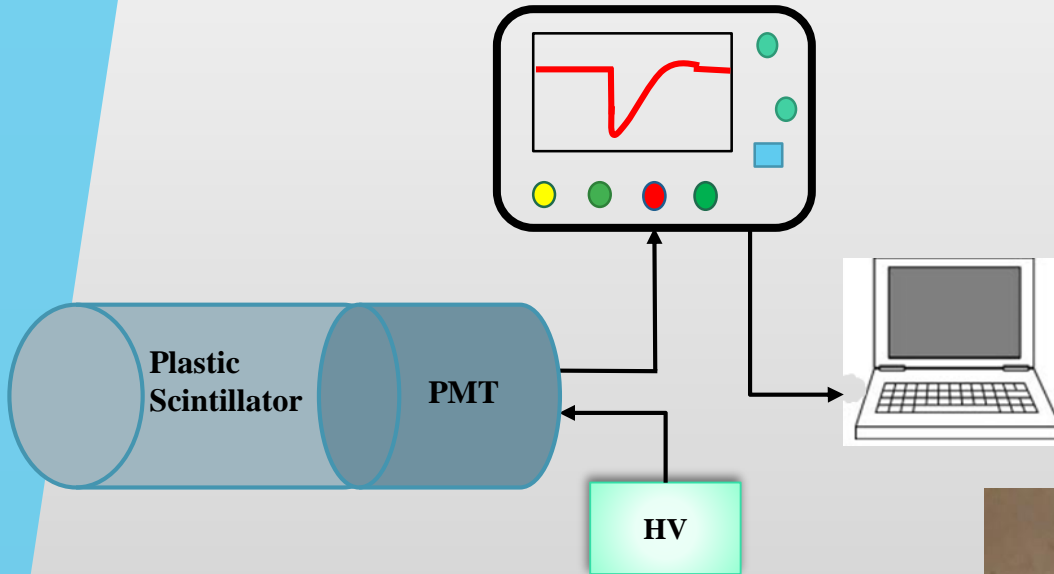

Data Acquisition system

C# program -> Data acquisition software written by Visual c#

A data-logger software written in C# language has been responsible for the data acquisition from a GDS-3504 digital oscilloscope. Both the data acquisition rate and connection port have been preset. Then, the storage location of pulse data as well as the time intervals have been determined. At the output, every anode pulse has been stored in either .txt or .csv format in a two-column matrix.

The data acquisition and analysis procedures were explained as following:

- (1) Mathematica and MATLAB softwares have been used for non-linear curvefitting and plotting the PMT as well as the scintillator anode pulses, respectively.
- (2) Having investigated the amplitude, rise time, fall time and the FWHM of the anode pulses, it has been decided to choose the FWHM as the most appropriate factor to discriminate the PMT pulses from those originating from plastic scintillator.
- (3) MATLAB has been used to discriminate and plot both the PMT and plastic scintillator 3D data according to their different FWHM values.
- (4) Finally, the 2D spectra corresponding the PMT and plastic scintillator have been plotted separately by MATLAB.

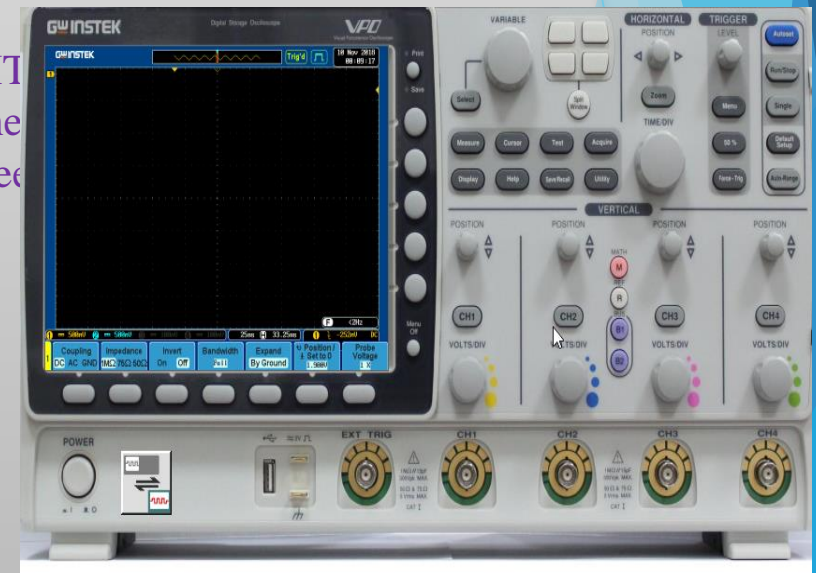

Experimental setup for coincidence detection of cosmic

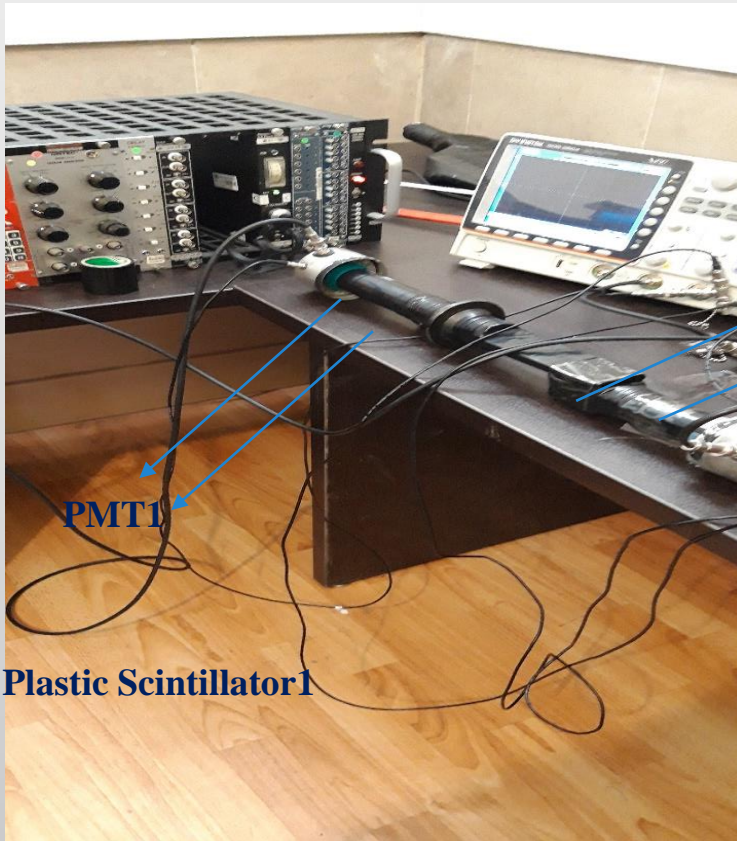

Data Acquisition

Digital Storage Oscilloscope

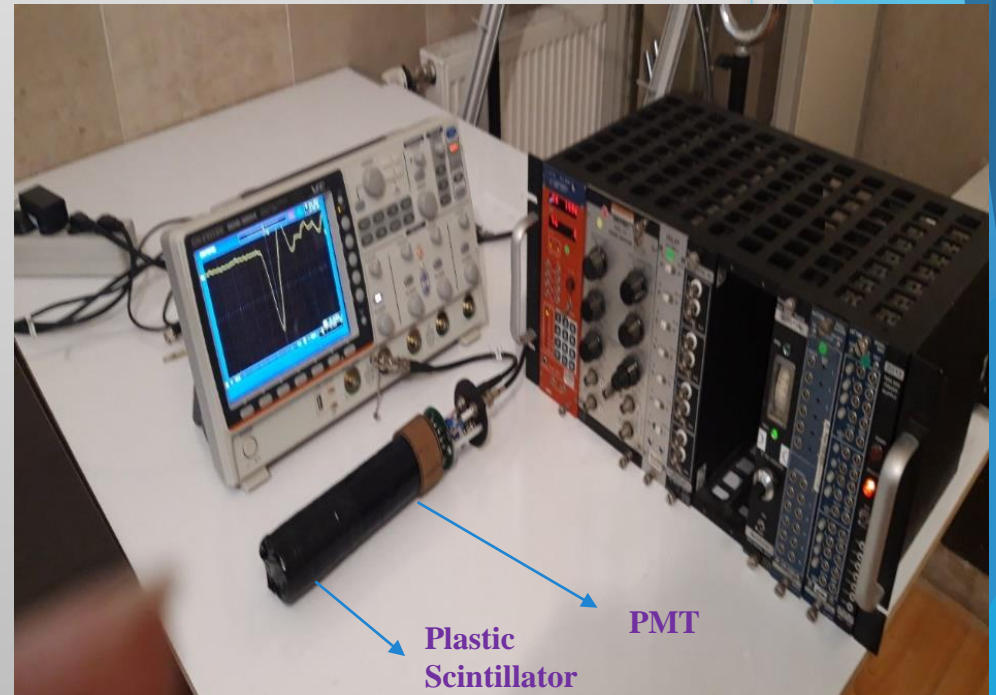
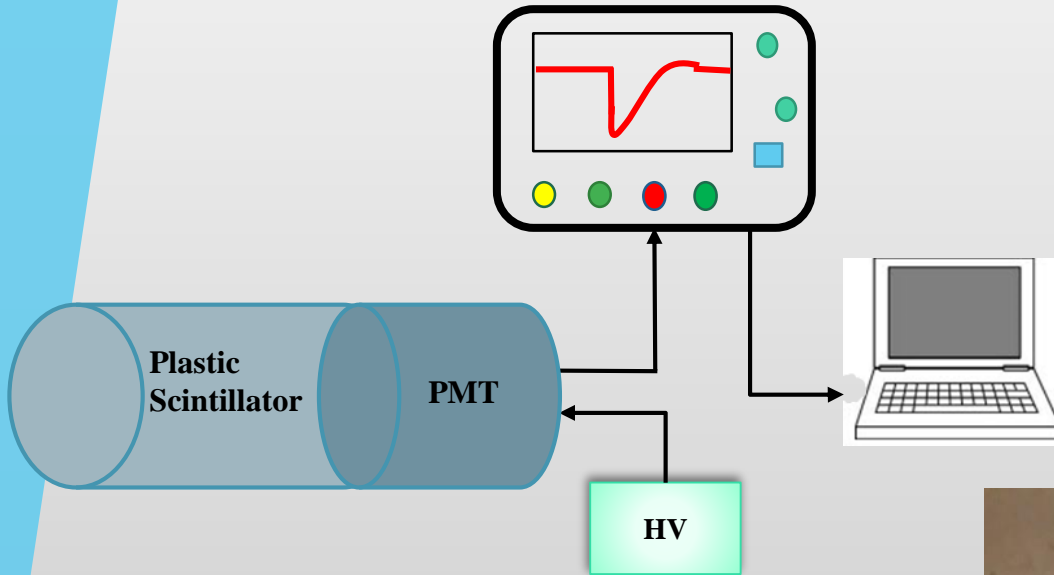

Materials and Methods

The block diagram of the proposed digital data-acquisition system used in three different setups. The measurement system consists of a 5.08 cm diameter by 5.08 cm long cylindrical NE102 plastic scintillator, two circular-face Photonis XP2020 PMTs with 52-mm diameter borosilicate glass windows, N570 CAEN high-voltage power supply, an 8-bit GDS3504 GW Instek digital oscilloscope with 4 GS/s sampling rate and different radioactive gamma-ray sources (^{60}Co (1 μCi), ^{137}Cs (1 μCi), ^{241}Am (1 μCi)). The anode pulse of the PMT with an output impedance of 50 Ω is fed into the oscilloscope which operates as a digitiser throughout the measurements.

Measurement set up

Setup 1

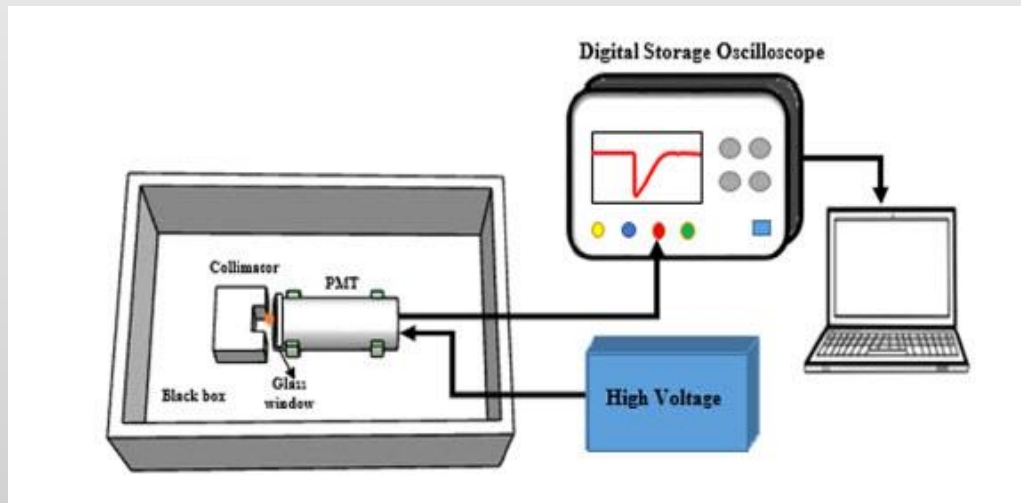

Setup 2

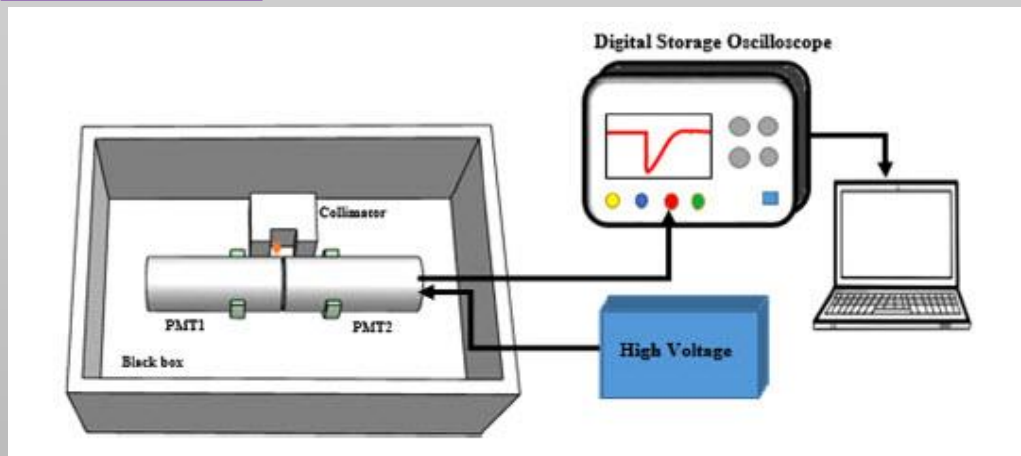

Setup 3

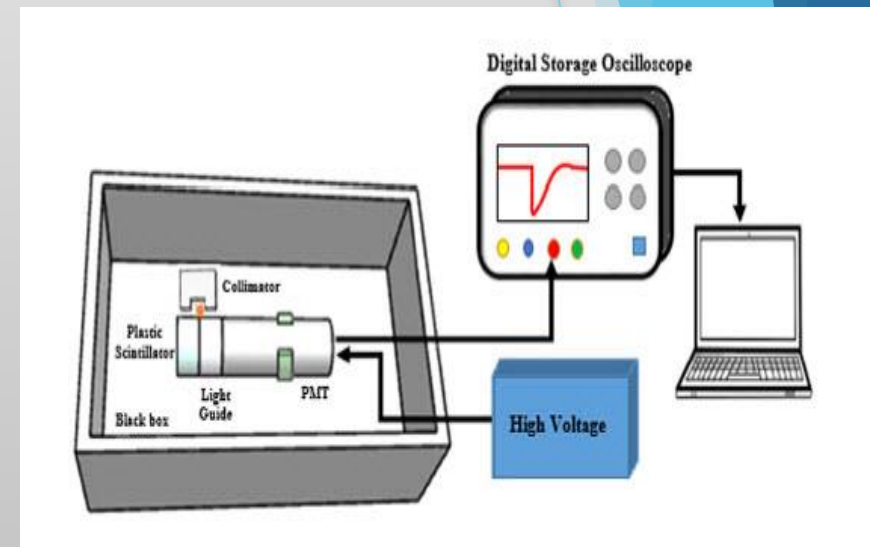

1) The spectra obtained from the detector with a bare PMT

The spectra obtained from the detector with a bare PMT (*i.e.*, without scintillator cell) when exposed to different point sources confirm the PMT sensitivity to both gamma-rays and the source type.

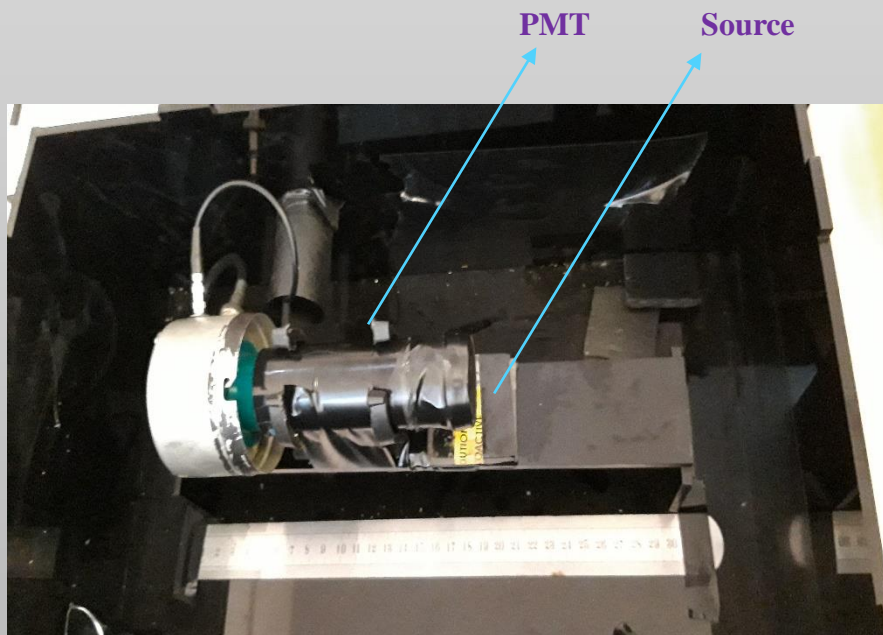
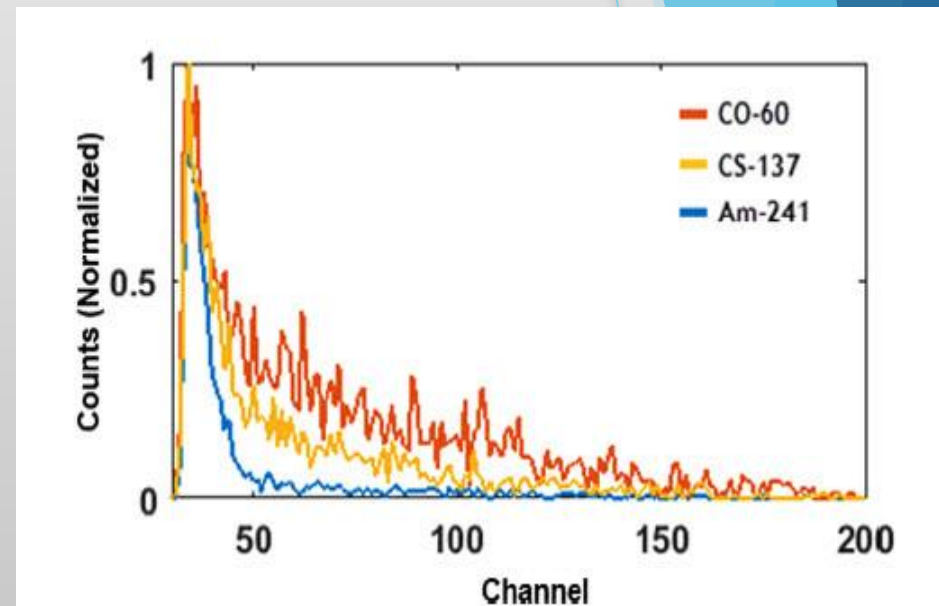
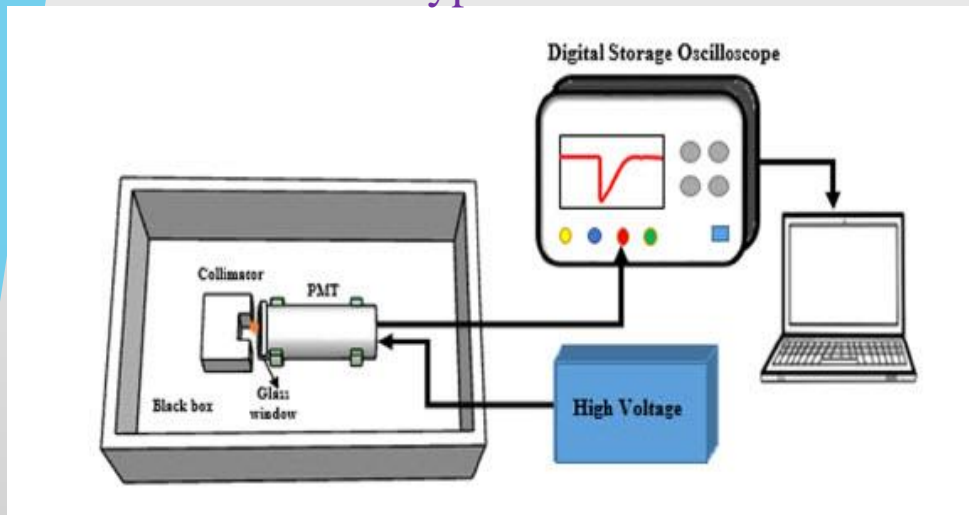

2) The count rates of the PMT output pulses measured with a bare PMT, with and without extra glasses, when exposed to ^{60}Co point source

The count rates of the PMT output pulses measured with a bare PMT, with and without extra glasses, when exposed to ^{60}Co point source are listed in Table 1. The voltage threshold for the counts measurements has been set as 20 mV. As it can be seen in Table 1, the count rate increases considerably with the addition of an extra glass to the PMT window and also it varies with the type of PMT glass.

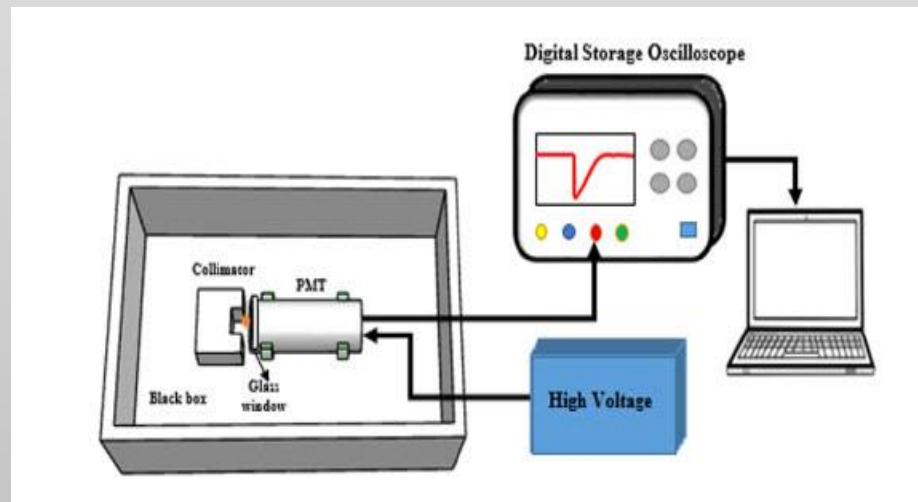

1

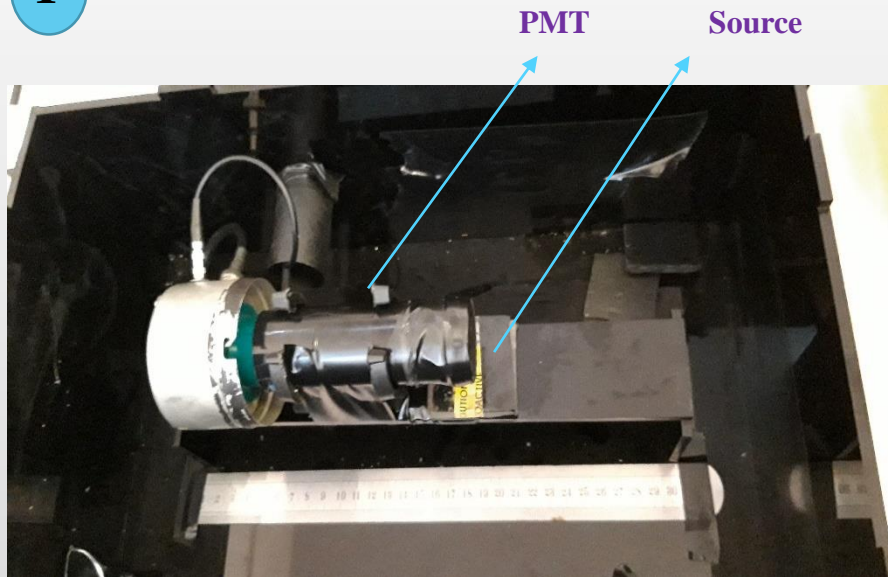

2

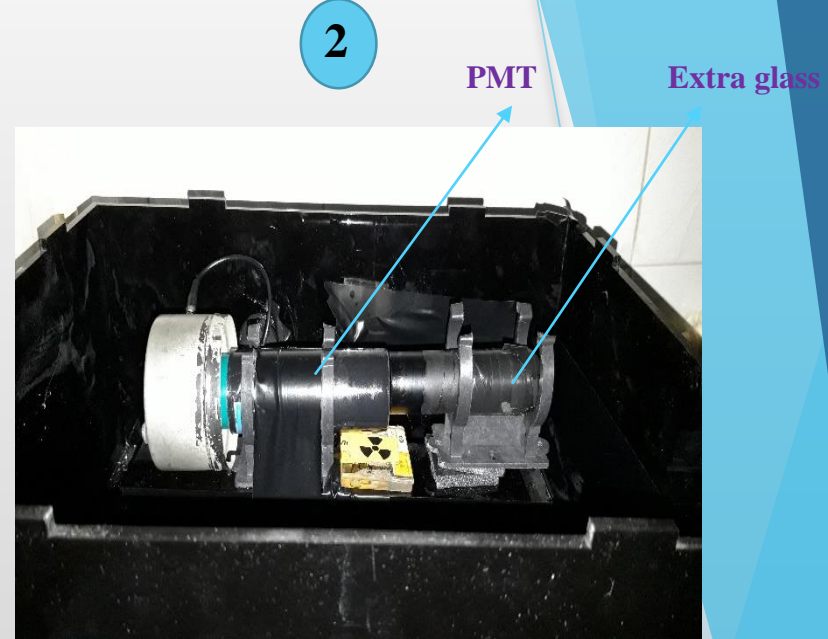

3

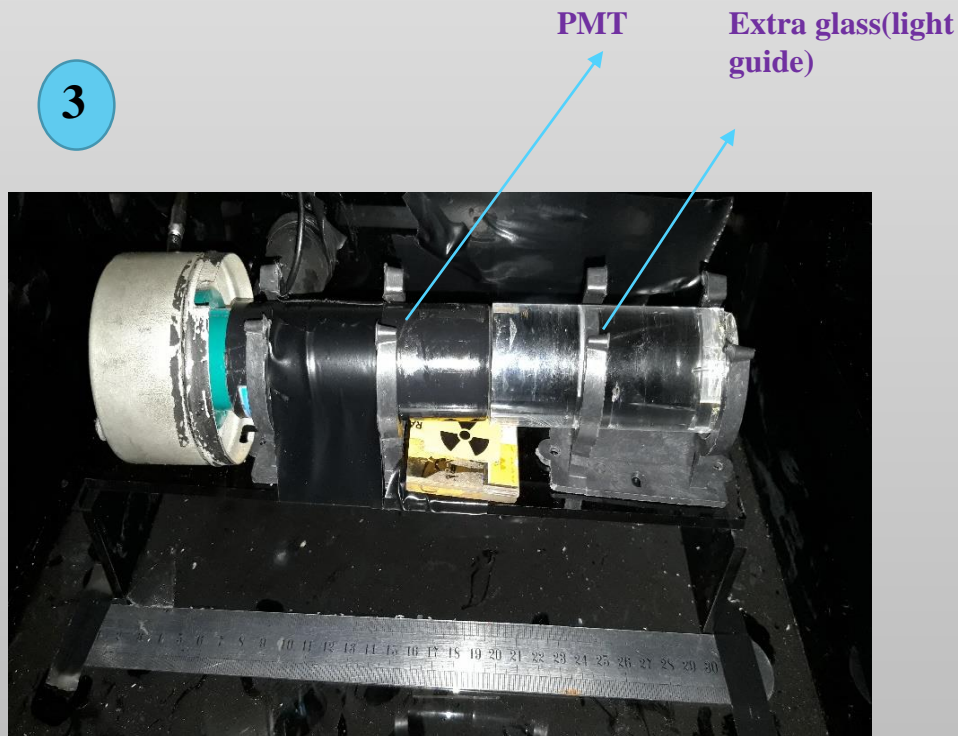

Table 1

The output signal count rates measured with the PMT of different glass window conditions.

PMT glass window condition	Source	Count rates
PMT without extra glass	BG ^a	30
	⁶⁰ Co	200
PMT with extra glass (i.e., two coupled PMTs)	BG	120
	⁶⁰ Co	800
PMT with BK7 glass	BG	70
	⁶⁰ Co	330
PMT with Lime glass	BG	55
	⁶⁰ Co	225

^aBG stands for background count rates.

3) The discrimination of the plastic scintillator pulse from the pulse originating from the PMT glass

- (1) The measurement setup where the PMT without plastic scintillator is exposed to $1\mu\text{Ci}$ ^{137}Cs point source and
- (2) The measurement setup, in which the detector assembly consisting the PMT and a plastic scintillator are attached through a 2-cm Plexiglas light guide, both exposed to $1\mu\text{Ci}$ ^{137}Cs point source.

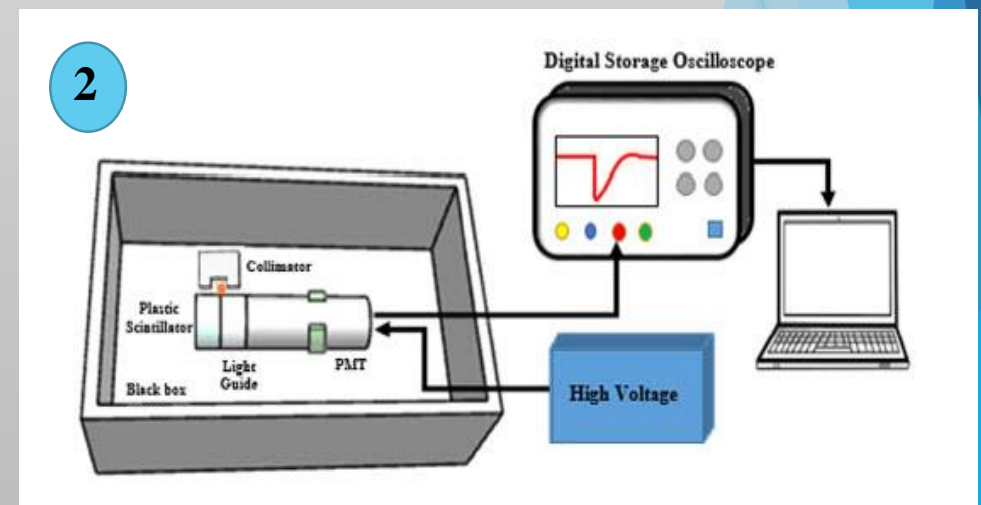
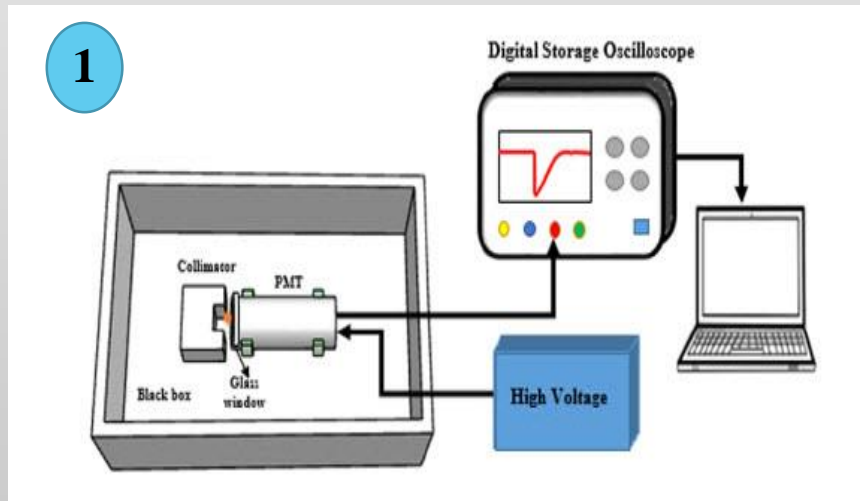

The measurement of pulse characteristics

- ✓ Different pulse characteristics such as rise time, fall time and FWHM have been extracted and processed. Finally, the output pulses originating from both the plastic scintillator and the PMT glass have been identified and discriminated.

- ✓ The pulses originating from the PMT represents low amplitudes due to the low Scintillation efficiency of the glass window, except those corresponding to high-energy cosmic rays, however, the plastic scintillator pulse-heights are relatively large.

The output pulses originating from both the plastic scintillator and the PMT glass

1

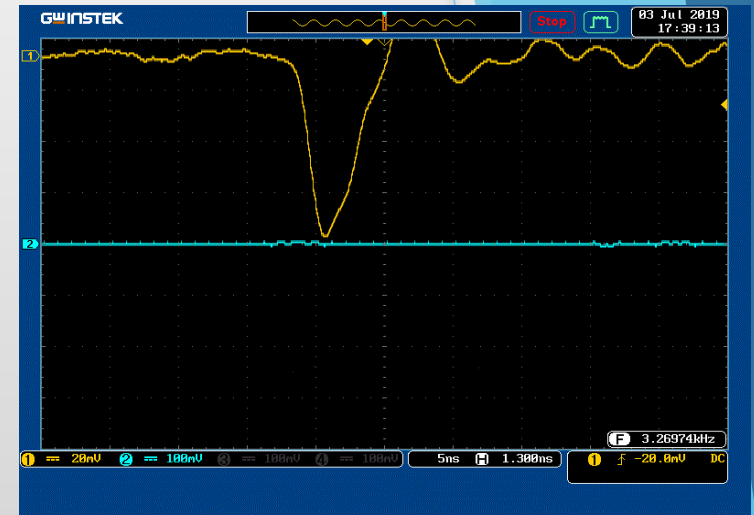
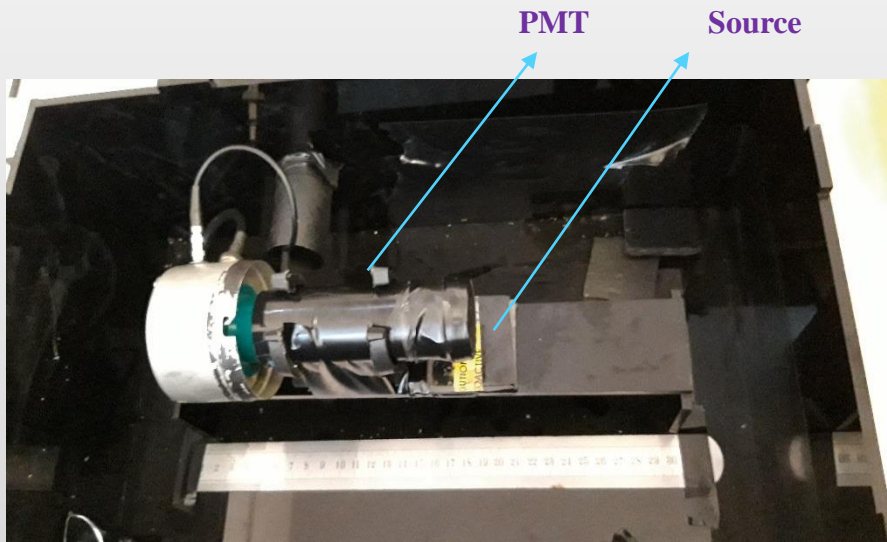

2

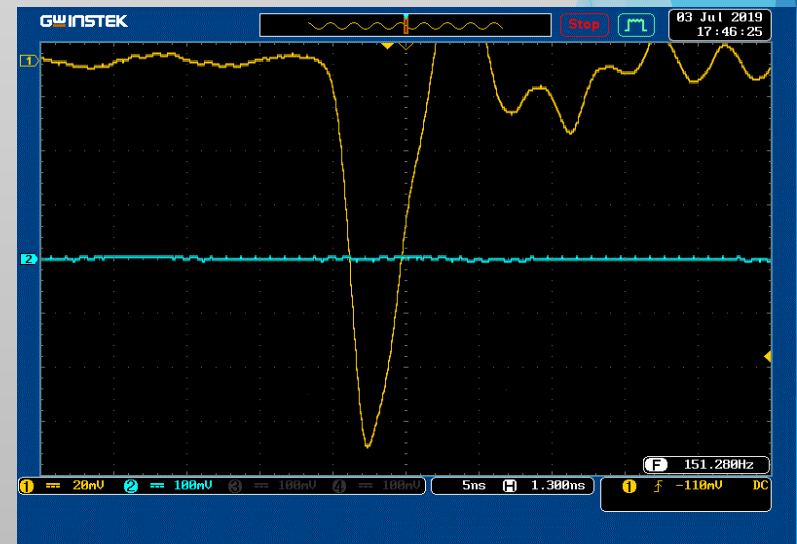
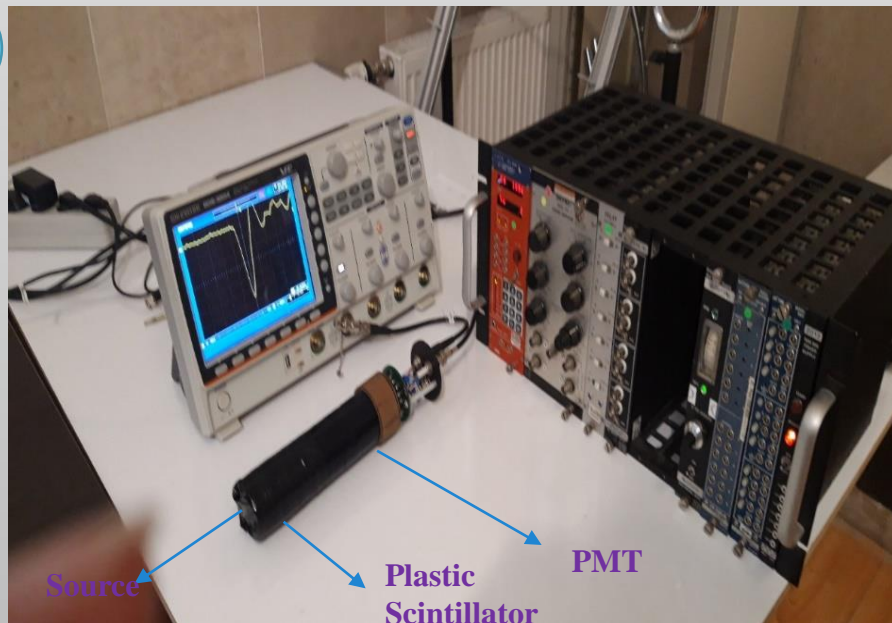

The output pulses originating from both the plastic scintillator and the PMT glass

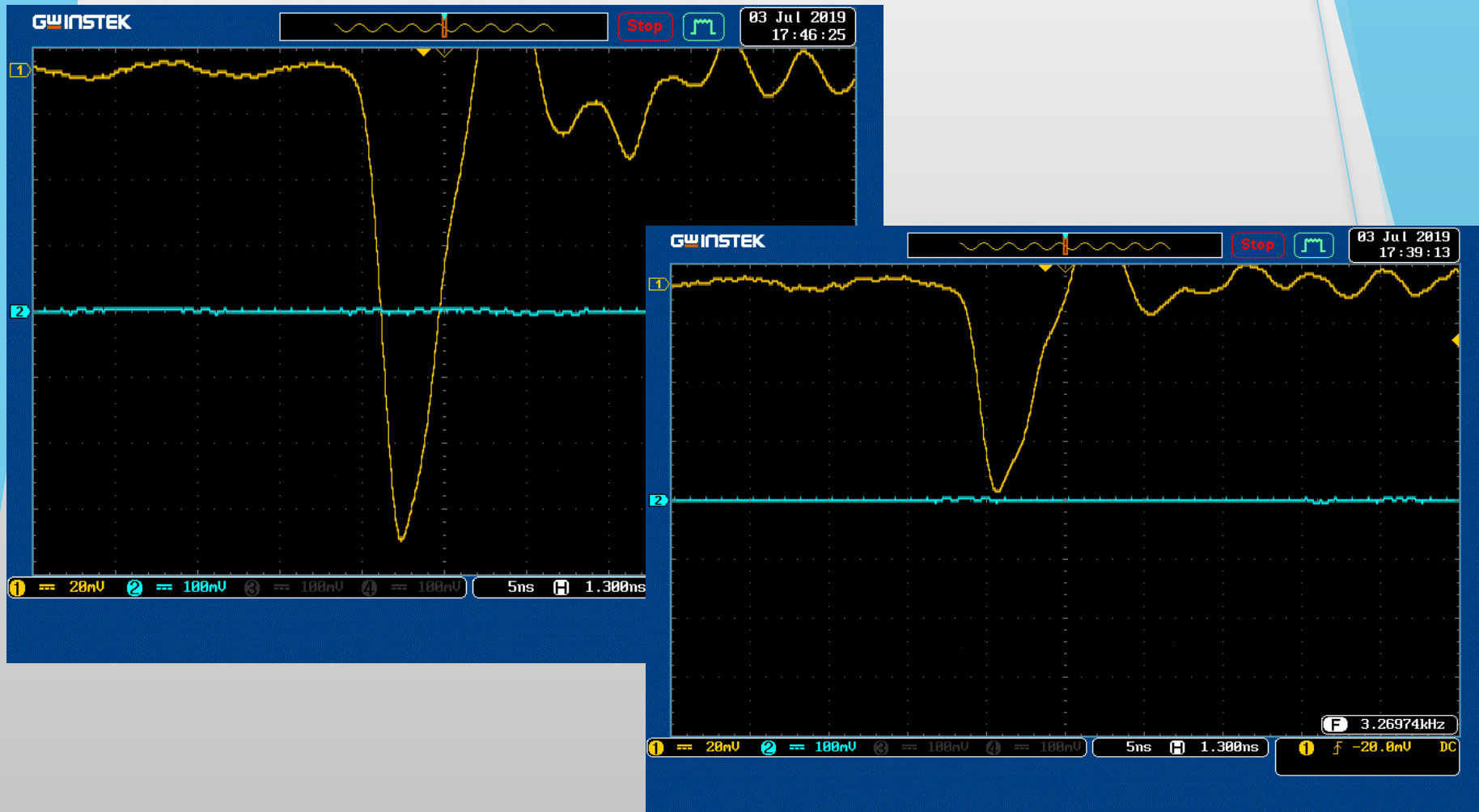

The pulses originating from the PMT represents low amplitudes due to the low scintillation efficiency of the glass window, except those corresponding to high-energy cosmic rays, however, the plastic scintillator pulse-heights are relatively large.

The discrimination of the plastic scintillator pulse from the pulse originating from the PMT glass

The time response of scintillators represent an exponential-decay form involving fast and slow components. A typical plastic scintillator time response is given in Eq. (1) where $N(t)$ and τ are the number of optical photons generated at time t and decay time constant, respectively.

$$N(t)=$$

Table 2

Fitting parameters calculated for the PMT output signals when the detector is with and without plastic scintillator.

Fitting parameters	PMT with plastic scintillator	PMT glass window
P1	1.582	1.561
P2	18.573	16.854
P3	4.477	5.165
P4	-0.047	0.017
P5	0.031	-0.066
P6	-0.576	-2.251

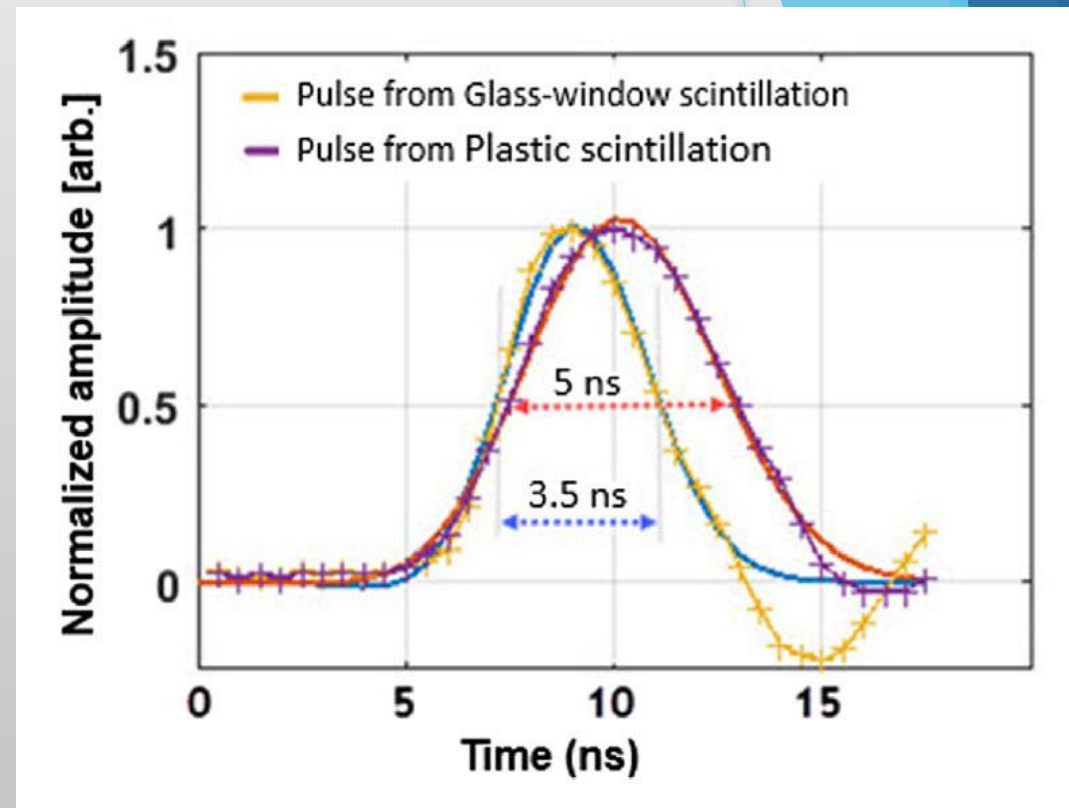

The statistical analyses undertaken on the output pulse characteristics showed that the majority of output pulses obtained from the bare PMT output pulses, have the FWHM of less than 4 ns. However, the pulses obtained from the PMT output pulses of the detector with the plastic scintillator, include the pulses with the FWHMs both less than and greater than 4 ns.

A 3D illustration of the scintillation detector pulses, where the discrimination was made in terms of different pulse FWHMs

A three-dimensional discrimination plot of the plastic scintillator-induced pulses versus those from PMT glass, using response function difference method. Whilst, the same discrimination plot for the assembly without plastic scintillator

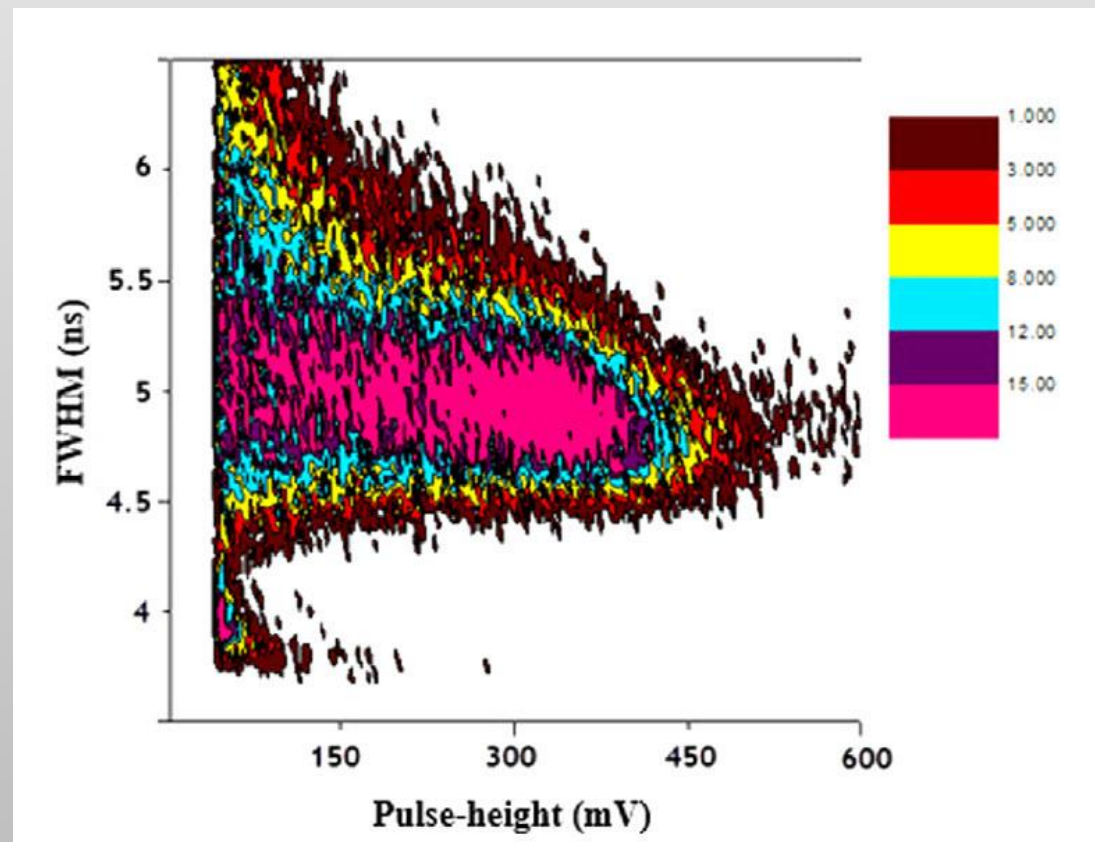

The measured spectra for the detectors with and without plastic scintillator when exposed to ^{137}Cs source along with the discriminated spectra.

The measured spectra correspond to the detector exposed to ^{137}Cs when both the PMT glass and scintillator cell contributions to the detector signal are taken into account as well as the discriminated spectra, where the two components are illustrated separately. As it can be seen, the discriminated spectrum is in agreement with the spectrum measured in bare PMT case.

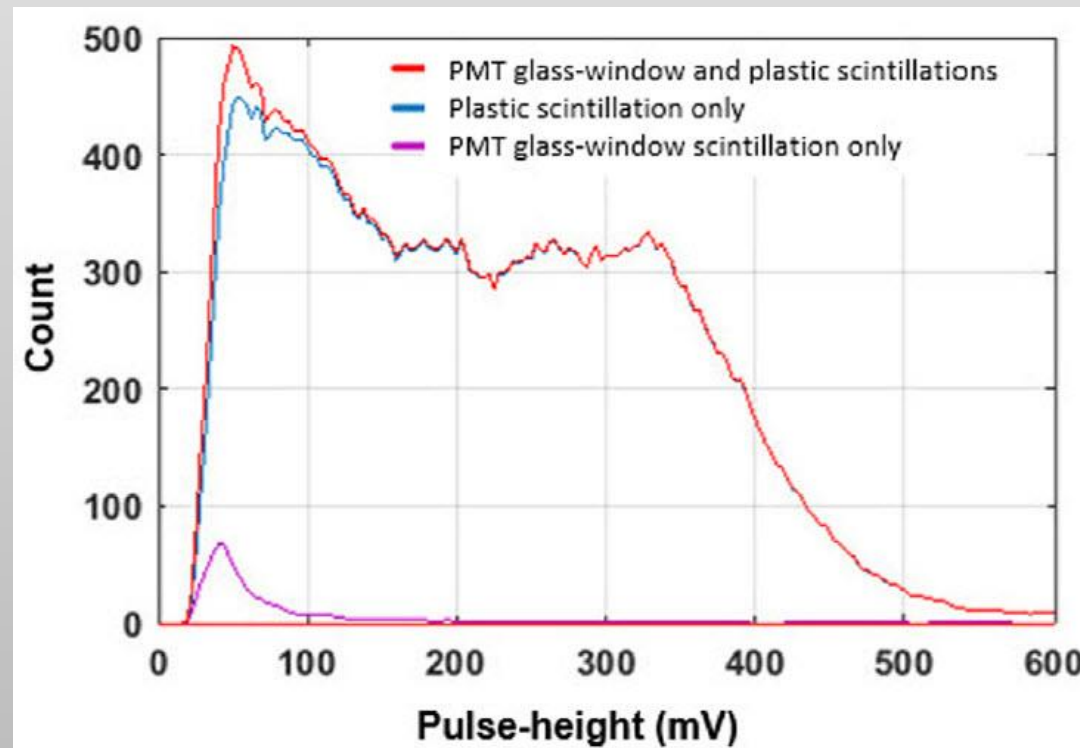

Conclusions

- According to measurement data, the major factor in PMT sensitivity is the glass window scintillation.
- As it can be seen, by adding a 3-mm thick extra glass to the PMT window, the count rate has increased from about 15 to 60 percent depending on the type and thickness of the glass.
- The time response of the PMT glass is considerably different from that of the plastic scintillator, where the discrimination can be simply made using the time features (e.g., FWHM).
- This discrimination capability is important in different applications such as time-of-flight and response function measurements when both scintillation and Cerenkov light may be present. The results confirm that the PMT coupled to a plastic scintillator may be regarded as a phoswich detector for an α - γ source (e.g., ^{241}Am), where a very thin plastic scintillator and the PMT glass window operate as alpha and gamma-ray spectrometers, respectively.

Thanks for your attention

